

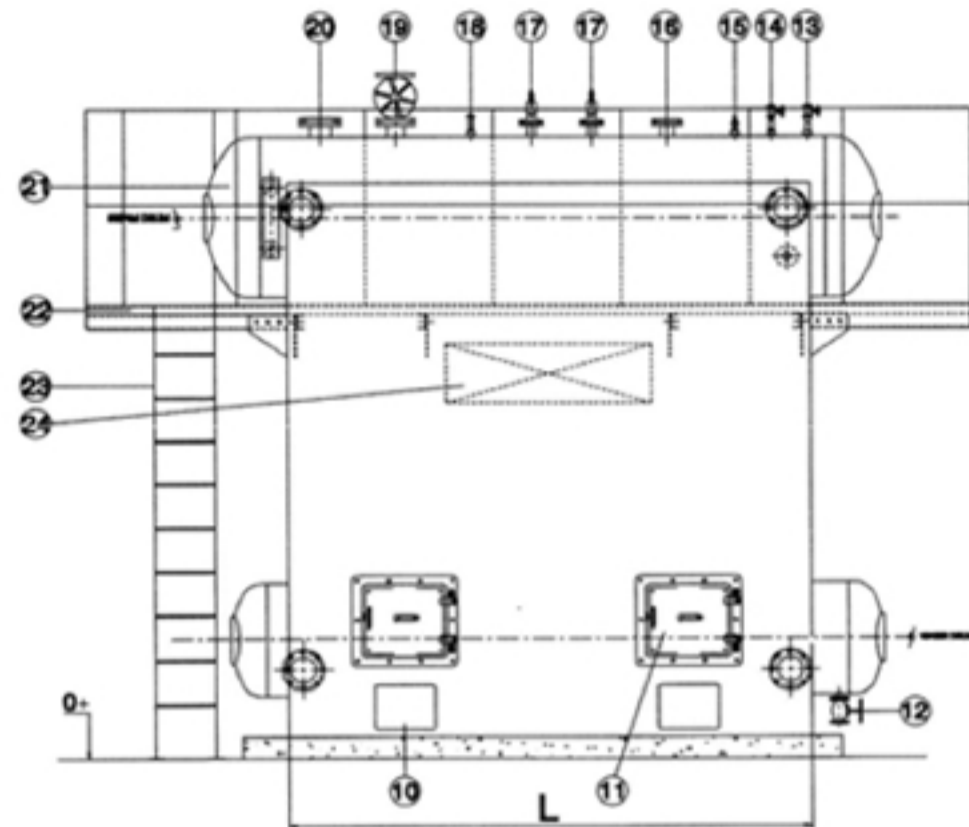

Tru-Steam Boilers & Service Pty Ltd
 Unit 3, 53-55 Governor Macquarie Drive
 Chipping Norton, NSW 2170
 +61297542166
 sales@trusteam.com.au
 www.trusteam.com.au

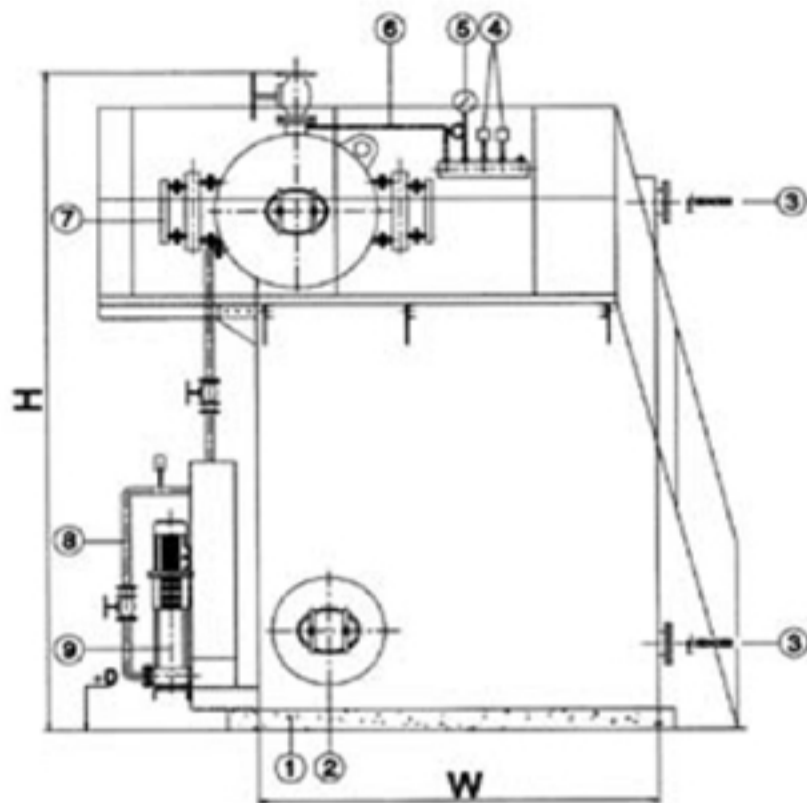

1. Concrete Plinth
2. Water Drum
3. Header
4. Pressure Relay
5. Pressure Gauge
6. Steam Piping into Pressure Gauge
7. Water Level Gauge
8. Feed Water Piping
9. Feed Water Pump
10. Cinder Output Door
11. Wood Waste Input Door
12. Blowdown Valve

13. Air Vent
14. Standby Steam Outlet
15. Water Level Limiter
16. Standby Steam Outlet
17. Safety Valve
18. Steam Piping into Pressure Gauge
19. Main Steam Valve
20. Standby Steam Outlet
21. Steam Drum
22. Platform
23. Ladder
24. Flue Exhaust

MODEL "WS"	5000	6000	8000	10000	12000	15000
CAPACITY KW	3300	4000	4500	6600	8000	10000
HP	330	400	450	660	800	1000
EVAPORATION KG/HR f & a 100 ⁰ C	5000	6000	8000	10000	12000	15000
HEATING SURFACE M ²	205.2	252	322	410	482	605
CONSUMPTION OF WASTE (KG/HR)	700	840	1120	1400	1680	2100
MAIN STEAM OUTLET (MM)	140	168	168	168	168	222
FEEDWATER INLET (MM)	49	49	60	60	60	60
SAFETY VALVE (MM)	60	60	60	60	76	76
BLOWDOWN VALVE (MM)	49	49	60	60	60	60
FLUE DIAMETER (MM) Ø	550	630	680	720	750	800
DIMENSIONS						
OVERALL HEIGHT (MM) H	4150	4150	4150	4150	4150	4150
OVERALL WIDTH (MM) W	2850	3000	3000	3000	3200	3400
OVERALL LENGTH (MM) L	3820	4200	5200	6000	7200	8500